

Loop-powered Hybrid Dewpoint Transmitter



MODEL HDT XTR-60 SENSOR



ATEX
IEC Ex

WITH XTR-60 SENSOR

-60°C to +30°C (-76°F to +86°F) (dp)

Extended Dewpoint Measurement Ranges Available

- Rugged, Waterproof, Fast, Accurate, HTF™ Aluminum Oxide Sensor Technology
- Loop-powered (2-wire) 5 to 28 VDC
 - Digital (HART Compliant) Output
 - Analog (4 to 20 mA) Output
- Programmable Alarm Signal
- Stainless Steel Housing
- IP65 Rated Connector (IP66 or IP67 Optional)
- Compact Design
- Temperature Compensated Calibration
- Suitable for installations at pressure or ambient

HTF™ High Capacitance Aluminum Oxide Sensor

The HDT uses a Xentaur Hyper-Thin-Film (HTF™) high capacitance aluminum oxide sensor with a measuring range of -60°C to +30°C (-76°F to +86°F)(dp). HTF™ sensors provide a degree of accuracy, speed of response and stability unavailable from instruments using conventional aluminum oxide or polymer sensors.

Sensor model XTR-60 is designed to work in tough, high pressure and even in liquid applications. The sensor is not affected by condensation and liquid water; once dried, it will resume measurement without requiring recalibration.

HART-compliant Transmitter

The model HDT is a HART compliant dewpoint transmitter, providing loop powered analog as well as a digital output. Housed in a 32mm (1.25") dia. stainless steel housing it has an overall length of 136mm (5.36"), including the Industrial Standard 9.4mm 4 pin connector. This makes the HDT the world's smallest loop-powered dewpoint transmitter.

Analog Output Loop

The instrument draws 4-20mA from the power supply. The 4-20mA is linear to the factory programmed units, eg. °C(dp) with an output resolution of 0.1°C(dp) or 0.25uA, whichever is greater. The output range is

programmable.

Digital Output Loop

The instrument can supply a digital output by modulating the 4-20mA loop line. The interface is defined by HART. In the digital mode the HDT can be remotely operated and the dewpoint as well as temperature can be read. In the digital mode multiple units can operate on the same loop cable as a multi-channel instrument. In this configuration each HDT draws a fixed 4mA independent of the measured dewpoint.

Built-in Alarm

The HDT provides a factory programmable dewpoint alarm signal through a digital output pin. Additionally, relays or external devices can be operated through the analog or digital loops.

Connections

The HDT interfaces with both metric 14mm X 1.25mm threads and unified 3/4"-16 threads. It is also available in other thread forms, refer to specifications. The HDT connects through an inexpensive two-conductor cable over long distances.

Measurement Accuracy/Stability

The HDT transmitter uses a multipoint calibration table which provides temperature compensated dewpoint readings for temperatures from -10°C to +70°C (+14°F to +158°F). Thus, the HDT provides accurate dewpoint measurements over its full range even under extreme

Typical sample system for measuring at atmospheric pressure

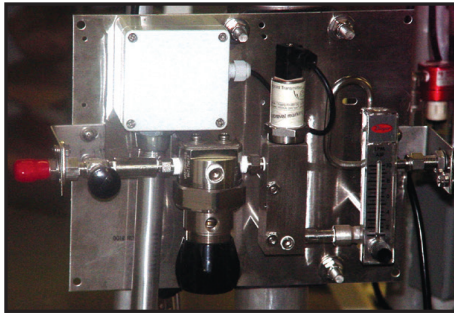

Digital display panel meter provides power and display; relays are optional



Specifications of HDT

- The HDT is a loop powered HART enabled dewpoint transmitter.
- HousingStainless Steel, weatherproof
- Dimensions & Weight~32mm (1.24") Dia. x ~136mm (5.36") long including sensor & connector; 227 g (0.5 lbs.)
- Pressure operating range Standard: 34 bar (500 psig). Optional: 340 bar (5,000 psig)
- Operating Temperature -30°C to +84°C (-22°F to +176°F)
- Mechanical connection 14mm x 1.25mm threads, and 3/4"-16 threads; other threads upon request 5/8"-18 UNF, G1/2", 1/2" NPT
- Electrical connectionsIndustrial Standard 9.4 mm, 4 pin connector. IP65 (IP66 or IP67 optional)
- CableTwo conductor cable. Min. #24AWG; for total cable length >1500m (5000') min. #20AWG (Cable must be shielded to meet CE requirements.)
- Power Requirements: 5 to 28 VDC, reverse polarity protected, the instrument draws 4-20mA depending on measured dewpoint
- Input resolution 0.1°C(dp)
- Indicators None
- Engineering units Factory programmed °C(dp), °C(t), °F(dp), ppmV, LBS H₂O/mm scf, gm H₂O/M³, ppmW, vapor pressure
- Controls HART interface, user's selections are stored in EEPROM
- Outputs:Analog and digital outputs are available.
 - A. 4-20mA drawn by the instrument from the power supply. The 4-20mA is linear to engineering units, the range is programmable. Output resolution is 0.1°Cdp or ~0.25uA whichever is greater.
 - B. The instrument can supply digital output by modulating the 4-20mA loop line. The interface is defined by HART. In the digital mode the HDT can be remotely operated and the dewpoint as well as temperature can be read. In the digital mode multiple

units can operate on the same loop cable as a multi-channel instrument. In this configuration each HDT draws only 4mA independent of the measured dewpoint.

AlarmsThe 4-20mA signal may be used by an external device to operate relays. In addition, a digital output pin is provided which can be factory (or specially equipped customer) programmed to provide dewpoint alarm indications.

Isolation:Sensor is connected to the current loop but isolated from the transmitter housing and installation threads

Warranty:..... 1 year

Specifications of HTF™ Dewpoint Sensor Element XTR-60

- TypeHyper-Thin-Film (HTF™) high capacitance Al₂O₃
- Dewpoint range-60°C to +30°C (-76°F to +86°F), other ranges available
- Capacitance.....15nF to 200nF
- Accuracy±2°C (±3.6°F)
- Repeatability.....±0.2°C (±0.36°F)
- Temperature Range.....-10°C to +70°C (+14°F to +158°F)
- Sample flow range:
 - (linear vel. @ 1 atm)Static to 100 m/s
- Storage temperature-40°C to +70°C (-40°F to +176°F)
- Calibration methodNIST/NPL traceable multipoint calibration table with temperature compensation over the full range

Approvals/Classifications

- Factory Mutual Approvals
- IS Class I, II, III, Division 1, Groups A, B, C, D, E, F, G T6 at 40°C ambient; T4 at 85°C max ambient
- Class I, Zone 0, AEx ia IIC T6 (-20 ≤ T_b ≤ 40°C); T4 (-20 ≤ T_a ≤ 85°C)
- NI Class I, Division 2, Groups A, B, C & D; Suitable for Class II, Division 2, Groups E, F & G; and Class III, Division 2

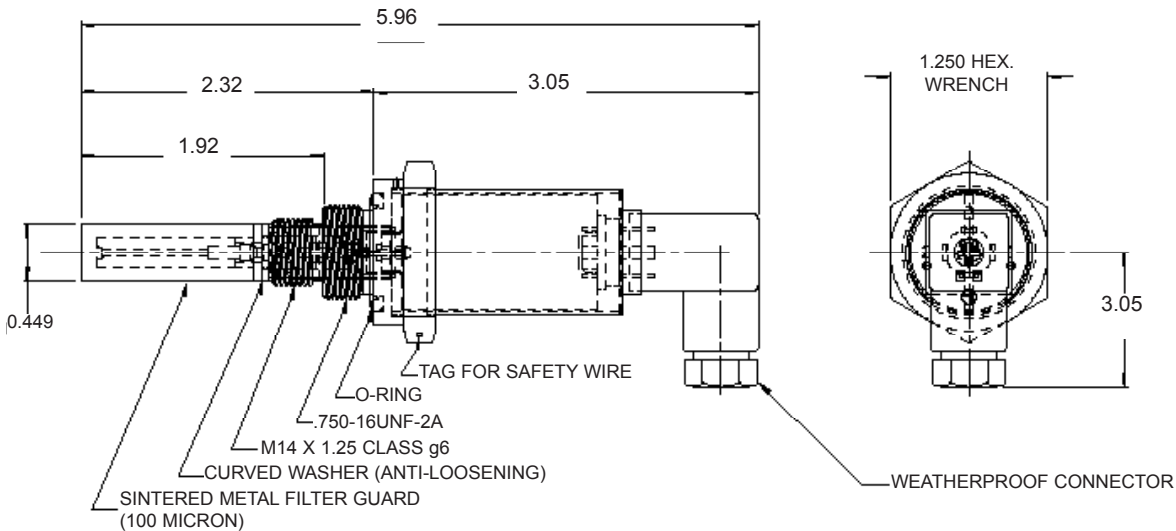

COSA Xentaur

84F Horseblock RD, Yaphank, NY 11980
 Phone: (631) 345 3434 Fax: (631) 924-7337
 email: sales@cosaxentaur.com
 www.cosaxentaur.com

